

Vacuum Pumps Designed for OEM, VACUUM FORMING / CHUCKING LAMINATION

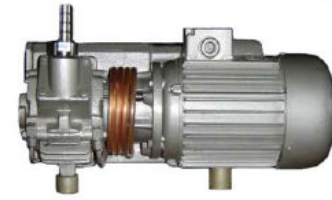

Rugged Economical Single Stage



General Dimensions
16" x 11" x 9"

The Viper Series VR-25 Single Stage Rotary Vane Vacuum Pumps are constructed of cast iron with ductile iron rotor, three aluminum alloy vanes, aluminum exhaust box and Viton lip seals. Pumps are easy to install, require no water, direct drive, oil free discharge, anti-suckback valve and gas ballasting to handle saturated loads.

Available Accessories:

- * Inlet Filters
- * Moisture Traps
- * Vacuum Gauges
- * Oxygen Service
- * Motor starters
- * Controls

TECHNICAL DATA

PUMP TYPE	VR-25		
Pump Capacity	CFM	15	
Rotational Speed	RPM	3550	
Ultimate Vacuum	Torr	2	
Motor (110V Single Phase)	HP	1.25	
Oil capacity	Qts	.5	
Noise level	db(A)	72	
Inlet/outlet connections	Inches	1/2	
Weight	Lbs	42	

VR-25

PERFORMANCE CURVE

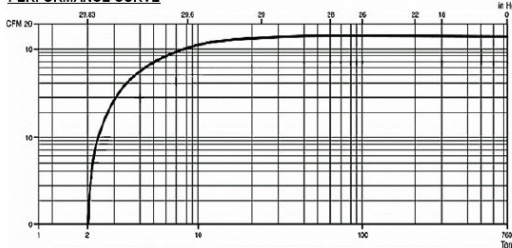

Typical applications include degassing, food packaging, food processing, drying, impregnation,

DIMENSIONS

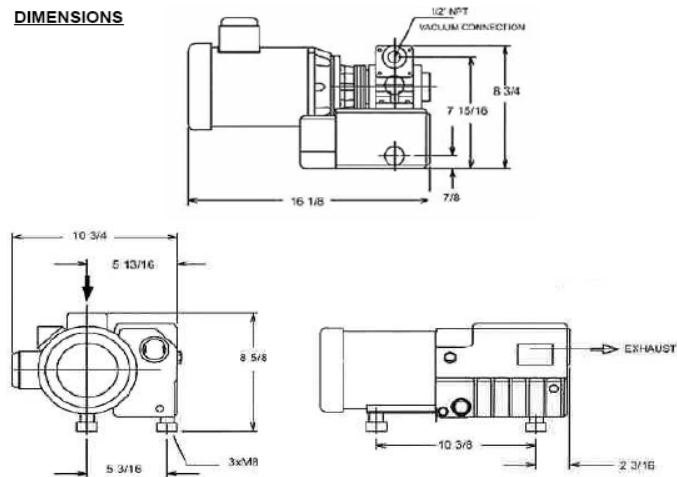

NOTE: Dimensions in inches